

UNITED STATES ENVIRONMENTAL PROTECTION AGENCY
REGION 7
11201 RENNER BOULEVARD
LENEXA, KANSAS 66219

IN THE MATTER OF) Docket No. CWA-07-2017-0108
)
Forterra Concrete Products, Inc.)
Shawnee, Kansas)
)
Respondent) COMPLAINT AND CONSENT
) AGREEMENT / FINAL ORDER
)
Proceedings under Section 309(g))
of the Clean Water Act,)
33 U.S.C. § 1319(g))
_____)

COMPLAINT

Jurisdiction

1. This is an administrative action for the assessment of civil penalties instituted pursuant to Section 309(g) of the Federal Water Pollution Control Act, commonly referred to as the Clean Water Act, 33 U.S.C. § 1319(g), and in accordance with the United States Environmental Protection Agency's ("EPA") Consolidated Rules of Practice Governing the Administrative Assessment of Civil Penalties and the Revocation/Termination or Suspension of Permits, 40 C.F.R. Part 22 ("Consolidated Rules of Practice").

2. This Complaint and Consent Agreement/Final Order ("CA/FO") alleges that Forterra Concrete Products, Inc. violated Section 301 of the CWA, U.S.C. § 1311, and a permit issued pursuant to Section 402 of the CWA, 33 U.S.C. § 1342, and regulations promulgated thereunder.

Parties

3. The authority to take action under Section 309(g) of the CWA, 33 U.S.C. § 1319(g), is vested in the Administrator of EPA. The Administrator has delegated this authority to the Regional Administrator of EPA, Region 7, who in turn has delegated it to the Director of the Water, Wetlands and Pesticides Division of EPA, Region 7 ("Complainant").

4. Forterra Concrete Products, Inc. (hereafter "Respondent" or "Forterra") is and was at all relevant times a corporation under the laws of, and authorized to conduct business in, the state of Kansas.

Statutory and Regulatory Framework

5. The objective of the CWA is to restore and maintain the chemical, physical, and biological integrity of the nation's waters. *See* Section 101(a) of the CWA, 33 U.S.C. § 1251(a).

6. Section 301(a) of the CWA, 33 U.S.C. § 1311(a), makes it unlawful for any person to discharge any pollutant from a point source to waters of the United States, except, *inter alia*, with the authorization of, and in compliance with, a National Pollutant Discharge Elimination System ("NPDES") permit issued pursuant to Section 402 of the CWA, 33 U.S.C. § 1342.

7. Section 502(5) of the CWA, 33 U.S.C. § 1362(5), defines "person" to include any individual, corporation, partnership, association, State, municipality, commission, political subdivision of a State, or any interstate body.

8. Section 502(6) of the CWA, 33 U.S.C. § 1362(6), defines "pollutant" to include, *inter alia*, rock, sand, and industrial waste discharged into water.

9. Section 502(14) of the CWA, 33 U.S.C. § 1362(14), defines "point source" to include "any discernable, confined and discrete conveyance, including but not limited to any pipe, ditch, channel, tunnel, conduit, well, discrete fissure, container, rolling stock, concentrated animal feeding operation, or vessel or other floating craft, from which pollutants are or may be discharged."

10. Section 502(7) of the CWA, 33 U.S.C. § 1362(7), defines "navigable waters" as the "waters of the United States," which are defined at 40 C.F.R. § 122.2 and which include tributaries to waters of the United States.

11. Section 402(p) of the CWA, 33 U.S.C. § 1342(p), sets forth requirements for the issuance of NPDES permits for the discharge of stormwater. That Section requires, in part, that a discharge of stormwater associated with an industrial activity must conform with the requirements of a NPDES permit issued pursuant to Sections 301 and 402 of the CWA.

12. Pursuant to Section 402(p) of the CWA, EPA promulgated regulations setting forth the NPDES permit requirements for stormwater discharges at 40 C.F.R. § 122.26.

13. 40 C.F.R. §§ 122.26(a)(1)(ii) and 122.26(c) require dischargers of stormwater associated with industrial activity to apply for an individual permit or to seek coverage under a promulgated stormwater general permit.

14. 40 C.F.R. § 122.26(b)(14)(ii) defines "stormwater discharge associated with industrial activity," in part, as facilities engaged in manufacturing concrete products classified within Standard Industrial Classification ("SIC") 32 (except 323).

15. Section 309(g) of the CWA provides for the assessment of civil penalties for violations of conditions or limitations in a permit issued pursuant to Section 402 of the CWA.

16. The Kansas Department of Health and Environment (“KDHE”) is the state agency with the authority to administer the federal NPDES program in Kansas pursuant to Section 402 of the CWA, 33 U.S.C. § 1342, and applicable implementing regulations. EPA maintains concurrent enforcement authority with authorized state programs for violations of NPDES permits.

EPA’s General Allegations

17. Respondent is a “person” as that term is defined in Section 502(5) of the CWA, 33 U.S.C. § 1362(5).

18. Respondent is and was at all times relevant to this action the owner and/or operator of a concrete product manufacturing facility operating under the name Forterra Concrete Products, Inc., located at 23600 W 40th Street, Shawnee, Kansas 66226 (“Facility”) and operating under SIC code 3272.

19. On or around October 1, 2015, Respondent purchased Cretex Concrete Products, including the Facility described in Paragraph 18 above.

20. Stormwater, snow melt, surface drainage, and runoff water leave the Facility and discharge to the Kansas River. The runoff and drainage from the Facility is “stormwater” as defined by 40 C.F.R. § 122.26(b)(13).

21. Stormwater from the Facility contains “pollutants” as defined by Section 502(6) of the CWA, 33 U.S.C. § 1362(6).

22. The Facility has “stormwater discharges associated with industrial activity” as defined by 40 C.F.R. § 122.26(b)(14)(ii), and is a “point source” as defined by Section 502(14) of the CWA, 33 U.S.C. § 1362(14).

23. The Kansas River is a “navigable water[.]” as defined by Section 502(7) of the CWA, 33 U.S.C. § 1362(7), and its implementing regulation, 40 C.F.R. § 122.2.

24. Stormwater runoff from Respondent’s industrial activity results in the addition of pollutants from a point source to waters of the United States, and thus is the “discharge of a pollutant” as defined by CWA Section 502(12), 33 U.S.C. § 1362(12).

25. Respondent’s discharge of pollutants associated with an industrial activity, as defined by 40 C.F.R. § 122.26(b)(14)(ii), requires a permit issued pursuant to Section 402 of the CWA, 33 U.S.C. § 1342.

26. KDHE issued General Permit Number KSR000783 to Cretex Concrete Products for the discharge of stormwater under the NPDES on August 16, 2012 (“Permit”). The Permit was effective from November 1, 2011 to October 31, 2016.

27. On April 12, 2016, KDHE approved a Notice of Transfer of Ownership of permit coverage from Cretex Concrete Products to Forterra. KDHE renewed Forterra’s Permit on November 1, 2016 with a new expiration date of October 31, 2021. The Permit governs stormwater discharges associated with industrial activities, including concrete product manufacturing.

28. Respondent has operated under the Permit at all times relevant to this Complaint.

29. On May 6, 2016, EPA performed an Industrial Stormwater Compliance Evaluation Inspection (hereafter “EPA Inspection”) of Respondent’s Facility under the authority of Section 308(a) of the CWA, 33 U.S.C. § 1318(a), to evaluate Respondent’s compliance with its Permit and the CWA.

30. During the EPA Inspection, the EPA inspector reviewed the records available at the Facility related to the Permit, and observed the Facility site and the receiving waters to which the Facility discharges stormwater.

Allegations of Violation

31. The facts stated above are herein incorporated.

Count 1

Inadequate Stormwater Pollution Prevention Plan (“SWPPP”) and Failure to Periodically Amend the SWPPP

32. Section 2.1 of Respondent’s Permit requires that the permittee develop a SWPPP, and periodically review and update as necessary the provisions of the SWPPP.

33. During the EPA Inspection, Respondent provided a copy of its SWPPP, prepared by Cretex Concrete Products. The EPA Inspection found that the SWPPP had not been reviewed or updated since May 2012 by either Cretex Concrete Products or Respondent. Respondent’s failure to review and update its SWPPP is a violation of the terms and conditions of Respondent’s Permit.

34. Section 2.4 of the Permit requires that the SWPPP contain certain minimum requirements. These requirements include, but are not limited to, a site map correctly identifying:

- a. The location of loading/unloading areas;

- b. The outlined drainage area and approximate acreage draining to each stormwater outfall; and
- c. The location of stormwater conveyances and area inlets for each stormwater outfall.

35. Appendix F of Respondent's SWPPP includes a site map of the Facility which does not identify the location of loading/unloading areas or the outlined drainage area and approximate acreage of each stormwater outfall. The site map also does not correctly identify the location of stormwater outfalls or the conveyances and area inlets for each stormwater outfall.

36. The site map in Respondent's SWPPP shows one outfall, Outfall 001, which is also labeled as the drain for the Facility's washout pit.

37. During the EPA Inspection, Respondent's representative informed the EPA inspector that the washout pit was originally designed and used to wash out concrete forms, but that the washout pit had become plugged and no longer discharged to Outfall 001. The EPA inspector was unable to verify this, but the EPA Inspection did find that stormwater from the Facility flows into an underground tile drainage system which conveys stormwater to the northwest corner of the Facility and into a large municipal stormwater collection system that drains to the Kansas River.

38. Based on the above findings, Respondent's SWPPP site map incorrectly identifies the location of stormwater conveyances and area inlets for stormwater outfall(s), and omits the outlined drainage area and approximate acreage of each stormwater outfall and location of loading/unloading areas.

39. Section 2.4.3(g) of the Permit requires that Respondent's SWPPP identify all unauthorized, non-stormwater (dry weather) discharges directed to surface water or groundwater. Any discharge of wastewater is an unauthorized non-stormwater discharge.

40. The EPA Inspection noted process wastewater generated by a concrete boring machine at the Facility pooling near an area inlet that discharges to the Kansas River. This process wastewater occasionally reaches the area inlet and discharges to surface water.

41. Respondent's SWPPP does not list any unauthorized non-stormwater discharges, including from the concrete boring machine.

42. Section 2.4.3 of the Permit requires reporting procedures, inspections, and maintenance activities to be developed and included in the SWPPP, including for routine site inspections, comprehensive site compliance evaluations, and visual examinations of stormwater quality.

43. Respondent's Permit requires quarterly routine site inspections (Section 2.4.3), annual visual examination of stormwater (Section 2.4.5), and an annual comprehensive site compliance evaluation (Section 2.4.4). The Permit has specific procedures and requirements for each of the three required inspections.

44. The "Facility Inspections" section of Respondent's SWPPP, Section 7.1, has one set of procedures and requirements for all inspections. The only inspections required by the SWPPP are quarterly inspections and inspections after every rainfall event over two inches. The inspection procedures and requirements that the SWPPP is missing, include, but are not limited to:

- a. For quarterly site inspections, that designated equipment and storage areas for chemicals, recycling equipment, paint, fueling, maintenance, loading/unloading, and waste management must be included, and that records of inspections must be maintained on-site in a readily accessible location for at least three years after the date of inspection.
- b. For the annual visual examination of stormwater, that a visual inspection of a stormwater discharge associated with industrial activity must be performed and documented at least once per year, and that each report shall include the nature of the discharge (runoff or snow melt), probable sources of any observed contamination, and shall be kept on-site or in a readily available location.
- c. For the annual comprehensive site compliance evaluation, that a report summarizing the evaluation, and summarizing any resolution to non-compliance found from the evaluation, including modification to the SWPPP, must be made and retained as part of the SWPPP.

45. Respondent's failure to incorporate all the procedures and reporting requirements for routine site inspections, comprehensive site compliance evaluations, and visual examinations of stormwater quality in its SWPPP is a violation of the Permit.

46. Each of Respondent's violations described above, is a violation of the terms and conditions of Respondent's permit, and as such, is a violation of Section 402(p) of the CWA, 33 U.S.C. § 1342(p), and EPA's implementing regulations.

Count 2

Unauthorized Discharges

47. Section 1.4 of Respondent's Permit states that the Permit does not authorize the discharge of sewage, pollutants, or wastewater.

48. During the EPA Inspection, the EPA inspector observed process wastewater being generated from the concrete boring machine and pooling near a stormwater drainage outlet. The

EPA inspector also noted that wastewater was generated from condensate during the steam curing process in the wet-casting area, which flowed to the concrete washout pit, designated as "Outfall 001" in Respondent's SWPPP. These discharges were not authorized by, or exempt from, an NPDES permit. The EPA Inspection findings indicate that Respondent's activities resulted in the discharge of process wastewater and in pollutants being deposited on exposed areas of the Facility where the pollutants were then conveyed in stormwater discharged to the Kansas River.

49. Respondent's unauthorized wastewater discharges are a violation of the terms and conditions of Respondent's Permit, and as such, are a violation of Sections 301(a) and 402(p) of the CWA, 33 U.S.C. §§ 1311(a) and 1342(p).

Count 3
Failure to Implement Adequate Control Measures or Take Sufficient
Corrective Actions to Improve Control Measures

50. Section 2.2 of the Permit requires Respondent to review, evaluate, select, install, utilize, operate, and maintain best management practices ("BMPs") in order to reduce the amount of pollutants in stormwater discharges associated with industrial activities at the Facility.

51. Section 2.1 of Respondent's Permit requires Respondent to fully implement its SWPPP, including implementing and periodically evaluating BMPs.

52. During the EPA Inspection, the EPA inspector found that Respondent had failed to implement and/or operate and maintain adequate BMPs to achieve compliance with the Permit, including, but not limited to, the following indications of inadequate control measures:

- a. Unauthorized wastewater discharges from the concrete boring machine and condensate from the steam curing process;
- b. The valve on the secondary containment structure for the north diesel fuel tank was missing, and therefore rendered the secondary containment structure ineffective;
- c. Form oil staining on the ground in the wet-casting area; and
- d. Grey dust and sediment covering much of the Facility grounds, indicating pollutants from concrete manufacturing are not being adequately controlled at the Facility.

53. Section 7.1 of Respondent's SWPPP requires Respondent to evaluate all structural and non-structural BMPs, on a quarterly basis, to determine their effectiveness and proper function. If a BMP needs to be significantly changed or updated, the SWPPP must be re-evaluated and modified within six weeks to incorporate these changes.

54. According to Respondent's SWPPP, Respondent's BMPs and SWPPP were last updated in May 2012. At the time of the EPA Inspection, Respondent had not reviewed, evaluated, or updated its SWPPP or BMPs since taking over operation of the Facility in October 2015.

55. The findings above indicate that Respondent has failed to adequately identify deficiencies in BMPs and modify its SWPPP to address these deficiencies. Respondent's failure to implement adequate control measures or take sufficient corrective actions to improve control measures is a violation of the terms and conditions of Respondent's Permit, and as such, is a violation of Section 402(p) of the CWA, 33 U.S.C. § 1342(p), and EPA's implementing regulations.

Count 4
Failure to Conduct and/or Document Routine Site Inspections

56. Section 2.4.3(d) of Respondent's Permit requires Respondent to conduct routine site inspections, at least quarterly, which include inspecting designated equipment and storage areas for raw materials, finished products, chemicals, recycling, equipment, paint, fueling, maintenance, loading/unloading, and waste management. An inspection report must be completed by facility personnel trained to conduct the inspection, must include completion dates for correction of all deficiencies found during the inspection, and must be maintained on-site for at least three years after the date of the inspection.

57. Section 7.1 of Respondent's SWPPP requires qualified personnel to conduct Facility inspections every quarter, which includes evaluating the Facility site conditions and any changes to the site, and evaluating all structural and non-structural BMPs. The SWPPP must be amended no later than six weeks after an inspection finds changes to the site, or deficiencies in the SWPPP or BMPs, among other findings.

58. At the time of the EPA Inspection, Respondent was unable to produce any inspection records for the two quarters during the time period Respondent took over ownership and operations of the Facility in October 2015 through the date of the EPA Inspection in May 2016.

59. Respondent's failure to conduct and/or document routine site inspections is a violation of the terms and conditions of Respondent's Permit, and as such, is a violation of Section 402(p) of the CWA, 33 U.S.C. § 1342(p), and EPA's implementing regulations.

CONSENT AGREEMENT

60. Respondent and EPA agree to the terms of this Consent Agreement/Final Order and Respondent agrees to comply with the terms of the Final Order.

61. Respondent admits the jurisdictional allegations of this CA/FO and agrees not to contest EPA's jurisdiction in this proceeding or any subsequent proceeding to enforce the terms of the Final Order.

62. Respondent neither admits nor denies the factual allegations contained in this Complaint and CA/FO.

63. Respondent waives any right to contest the allegations set forth in this CA/FO and its right to appeal this Consent Agreement and the accompanying Final Order.

64. Respondent and EPA agree to conciliate this matter without the necessity of a formal hearing and to bear their respective costs and attorney's fees incurred as a result of this action.

65. Respondent certifies by the signing of this CA/FO that to the best of its knowledge, Respondent is in compliance with all requirements of the CWA, 33 U.S.C. § 1251, *et seq.*, and all regulations promulgated there under.

Penalty Payment

66. Respondent agrees that, in settlement of the claims alleged in this CA/FO, Respondent shall pay a civil penalty of **Nine Thousand and Twenty Two Dollars (\$9,022)** pursuant to the authority of Section 309(g) of the CWA, 33 U.S.C. § 1319(g), to be paid in full no later than thirty (30) days after the effective date of this Consent Agreement/Final Order as set forth below.

67. The payment of penalties must reference docket number "CWA-07-2017-0108" and be remitted using one of the payment methods specified in Appendix A of this Order.

68. Copies of the check, or verification of another payment method for the penalty payment remitted as directed above, shall be sent to:

Regional Hearing Clerk
U.S. Environmental Protection Agency - Region 7
11201 Renner Boulevard
Lenexa, Kansas 66219

and to:

reitz.katherine@epa.gov or,
Katherine Reitz
Attorney Advisor
U.S. Environmental Protection Agency - Region 7
11201 Renner Boulevard
Lenexa, Kansas 66219.

69. Respondent agrees that no portion of the civil penalty or interest paid by Respondent pursuant to the requirements of this CA/FO shall be claimed by Respondent as a deduction for federal, state, or local income tax purposes.

70. Respondent understands that, pursuant to 40 C.F.R. § 13.18, interest on any late payment will be assessed at the annual rate established by the Secretary of the Treasury pursuant to 31 U.S.C. § 3717. The interest will be assessed on the overdue amount from the due date through the date of payment. Failure to pay the civil penalty when due may result in the commencement of a civil action in Federal District Court to collect said penalty, together with costs and interests.

Supplemental Environmental Project

71. Respondent agrees to undertake the Supplemental Environmental Project (“SEP”), identified in Appendix B, which is incorporated into this CA/FO. The parties agree that performance of the SEP is intended to secure significant environmental or public health protection and improvements.

- a. **Project Description:** Respondent will regrade portions of the Facility site, create approximately a 6 ft. x 650 ft. drainage swale, and install sediment and erosion controls to reduce pollutants discharged in stormwater. The regrading will redirect stormwater away from the outside production areas toward the northern boundary berm of the facility, reducing stormwater run-on of the production areas. The drainage swale will provide a vegetative swale for sedimentation as well as increasing infiltration of stormwater. A BioClean trash guard will be installed at the facility’s outfall to reduce pollutants discharged in stormwater.
- b. **SEP Cost:** The total expenditure for the SEP shall not be less than **Twenty Four Thousand Eight Hundred and Eighty Dollars (\$24,880)**.
- c. **Completion Date:** All work on the project shall be fully completed within 180-days from the effective date of this CA/FO.

72. Within thirty (30) days of the SEP Completion Date, as identified in Paragraph 71.c. above, Respondent shall submit a SEP Completion Report to EPA.

- a. The SEP Completion Report shall contain the following:
 - (i) A detailed description of the SEP as implemented;
 - (ii) Itemized costs, documented by copies of records such as purchase orders, receipts, or canceled checks; and

- (iii) The following certification signed by Respondent or its authorized representative:

I certify under penalty of law that I have examined and am familiar with the information submitted in this document and all attachments and that, based on my inquiry of those individuals immediately responsible for obtaining the information, the information is true, accurate, and complete. I am aware that there are significant penalties for submitting false information, including the possibility of fines and imprisonment for knowing violations.

- b. The SEP Completion Report and all other submittals regarding the SEP shall be submitted electronically to:

trainor.erin@epa.gov

Documents that cannot be submitted electronically to EPA shall be submitted to:

Erin Trainor, or her successor
Environmental Field Compliance Branch
U.S. Environmental Protection Agency, Region 7
300 Minnesota Ave.
Kansas City, Kansas 66101

- c. Respondent agrees that failure to submit the SEP Completion Report required by subsections a. and b. above shall be deemed a violation of this CA/FO and Respondent shall become liable for stipulated penalties as described in Paragraph 73, below.

73. Stipulated Penalties for Failure to Complete SEP/Failure to Spend Agreed-upon Amount:

- a. In the event that Respondent fails to comply with any of the terms or provisions of this CA/FO relating to the performance of the SEP, and/or to the extent that the actual expenditures for the SEP do not equal or exceed the SEP Cost described in Paragraph 71.b., Respondent shall be liable for stipulated penalties according to the provisions set forth below:
- (i) Except as provided in subparagraph (ii) and (iii) immediately below, for a SEP which has not been completed satisfactorily pursuant to this CA/FO, Respondent shall pay a stipulated penalty to the United States in the amount of Fourteen Thousand Eight Hundred and Twenty Five Dollars (\$14,825);

- (ii) If the SEP is completed in accordance with Paragraph 71 and Appendix B, but the Respondent spent less than 90 percent of the amount of money required to be spent for the project, Respondent shall pay a stipulated penalty to the United States equal to the difference between the amount of the estimated SEP Cost set forth in Paragraph 71.b. and the amount actually expended in implementing the SEP;
 - (iii) Respondent shall not be liable for stipulated penalties if:
 - (a) The SEP is not completed in accordance with this CA/FO, but the Complainant determines that the Respondent: (1) made good faith and timely efforts to complete the project; and (2) certifies, with supporting documentation, that at least 90 percent of the amount of money which was required to be spent was expended on the SEP; or
 - (b) The SEP is completed in accordance with this CA/FO, and Respondent certifies, with supporting documentation, that Respondent spent at least 90 percent of the amount of money required to be spent for the project; and
 - (iv) Respondent shall pay a stipulated penalty in the amount of \$100 for each day it fails to submit the SEP Completion Report after the due date specified in Paragraph 73, until the report is submitted.
- b. Payment of stipulated penalties shall be immediately due and payable upon notice by EPA. Interest and late charges shall be paid as described in Paragraph 70 above.
 - c. The EPA may, in its discretion, reduce or waive stipulated penalties otherwise due under this CA/FO.

74. Respondent hereby certifies that, as of the date of this CA/FO, Respondent is not required to perform or develop the SEP by any federal, state, or local law or regulation, and is not required to perform or develop the SEP by agreement, grant, or as injunctive relief in any other action in any forum. Respondent further certifies that Respondent has not received and will not receive credit for the SEP in any other enforcement action.

75. Respondent certifies that all cost information provided to EPA in connection with EPA's approval of the SEP is complete and accurate and that Respondent, in good faith, estimates that the cost to implement the SEP is at least **Twenty Four Thousand Eight Hundred and Eighty Dollars (\$24,880)**.

76. Respondent agrees that, for federal income tax purposes, Respondent will not deduct any costs or expenditures incurred in performing the SEP.

Effect of Settlement and Reservation of Rights

77. Respondent's payment of the entire civil penalty and completion of SEPs pursuant to this Consent Agreement/Final Order resolves all civil and administrative claims pursuant to Section 309(g) of the CWA, 33 U.S.C. § 1319(g), for alleged violations identified in this Compliant and Consent Agreement/Final Order. Complainant reserves the right to take any enforcement action with respect to any other violations of the CWA or any other applicable law.

78. This CA/FO shall apply to and be binding upon Respondent, its agents, successors, and assigns. Respondent shall ensure that its directors, officers, employees, contractors, consultants, firms, or other persons or entities acting under or for them with respect to matters included herein comply with the terms of this CA/FO.

79. Notwithstanding any other provision of this CA/FO, EPA reserves the right to enforce the terms of this CA/FO by initiating a judicial or administrative action pursuant to Section 309 of the CWA, 33 U.S.C. § 1319, and to seek penalties against Respondent or to seek any other remedy allowed by law.

80. With respect to matters not addressed in this CA/FO, EPA reserves the right to take any enforcement action pursuant to the CWA, or any other available legal authority, including without limitation, the right to seek injunctive relief, penalties, and damages.

81. EPA reserves the right to enforce the terms of this CA/FO by initiating a judicial or administrative action pursuant to Section 309 of the CWA, 33 U.S.C. § 1319.

General Provisions

82. Parties acknowledge that this Consent Agreement/Final Order is subject to public notice and comment requirements pursuant to Section 309(g)(4) of the CWA, 33 U.S.C. § 1319(g)(4), and 40 C.F.R. § 22.45.

83. The headings in this Consent Agreement/Final Order are for convenience of reference only and shall not affect interpretation of this Consent Agreement/Final Order.

84. Respondent and Complainant agree that this Consent Agreement/Final Order may be signed in part and counterpart.

85. The effect of settlement is conditional upon the accuracy of the Respondent's representations to EPA.

86. Nothing contained in the CA/FO shall alter or otherwise affect Respondent's obligations to comply with all applicable federal, state, and local environmental statutes and regulations and applicable permits, nor shall it be construed to be a ruling on, or determination of, any issue related to any federal, state, or local permit.

87. The undersigned representative(s) of Respondent certifies that he or she is fully authorized to enter the terms and conditions of this Complaint and CA/FO and to execute and legally bind Respondent to it.

Effective Date

88. Pursuant to 40 C.F.R. § 22.31(b), this Consent Agreement/Final Order shall be effective on the date the Final Order is filed with the Regional Hearing Clerk, U.S. Environmental Protection Agency, 11201 Renner Boulevard, Lenexa, Kansas 66219. All time periods herein shall be calculated therefrom in calendar days unless otherwise provided in this CA/FO.

COMPLAINANT:
U.S. ENVIRONMENTAL PROTECTION AGENCY

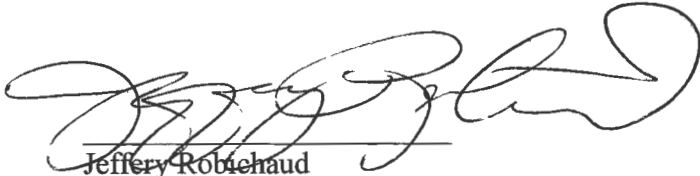

Jeffery Robichaud
Acting Director
Water, Wetlands and Pesticides Division

9/20/17
Date

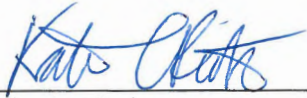

Katherine Reitz
Attorney Advisor

9/20/17
Date

RESPONDENT:
FORTERRA CONCRETE PRODUCTS, INC.



MARK CARPENTER
Name

July 19, 2017
Date

PRESIDENT
Title

FINAL ORDER

Pursuant to 40 C.F.R. 22.18(b)-(c) of EPA's Consolidated Rules of Practice, the foregoing Consent Agreement resolving this matter is incorporated by reference into this Final Order and is hereby ratified.

The Respondent is ORDERED to comply with all terms of the Consent Agreement. In accordance with 40 C.F.R. § 22.31(b), the effective date of the foregoing Consent Agreement and this Final Order is the date on which this Final Order is filed with the Regional Hearing Clerk.

IT IS SO ORDERED.

Sept. 25, 2017
Date

Karina Borromeo
Karina Borromeo
Regional Judicial Officer

**APPENDIX A
PENALTY PAYMENT INFORMATION**

Further information regarding making payments to the U.S. EPA may be found at:

<http://www.epa.gov/financial/makeapayment>

Cashier's or Certified Check: If payment is being made by cashier's or certified check, submit the check, including the name and docket number of this case, payable to "Treasurer, United States of America":

By U.S. Postal Service:

U.S. Environmental Protection Agency
Fines and Penalties
Cincinnati Finance Center
P.O. Box 979077
St. Louis, MO 63197-9000

By Common Carrier (Fedex, DHL, UPS):

U.S. Environmental Protection Agency
Government Lockbox 979077
1005 Convention Plaza
Mail Station SL-MO-C2-GL
St. Louis, MO 63101

Online Payment: Online payment is available through the Department of Treasury and can be accessed using the information below.

www.pay.gov

Enter "SFO 1.1" (without quotation marks) in the SEARCH field. The first search result should be titled "EPA Miscellaneous Payments – Cincinnati Finance Center," SFO Form Number 1.1. Click on the red button that says, "Continue to the form."

Complete the required fields and pay with a bank account (ACH) or debit/credit card. Keep a copy of the confirmation page for your records.

Wire Transfers: If payment is being made by wire transfer, the wire transfer must indicate the name and docket number of this case and be sent to the Federal Reserve Bank in New York City with the following information:

Federal Reserve Bank of New York
ABA: 021030004
Account Number: 68010727
SWIFT address: FRNYUS33
33 Liberty Street
New York, NY 10045

Field Tag 4200 of the Fedwire message should read: “D 68010727 Environmental Protection Agency”

Automated Clearing House (ACH) or Remittance Express (REX): If using ACH or REX, payments must indicate the name and docket number of the case and can be made through the U.S. Treasury using the following information:

U.S. Treasury REX/Cashlink ACH Receiver
ABA: 051036706
Account Number: 310006, Environmental Protection Agency
CTX Format
Transaction Code 22 – checking
Physical location of U.S. Treasury Facility:
5700 Rivertech Court
Riverdale, MD 20737
U.S. Treasury Contact Information:
John Schmid: 202-874-7026
Remittance Express (REX): 1-866-234-5681

Payment Tips: To ensure proper credit please include the following information on your payment:

- Company/remitter’s name (as it appears on EPA document)
- Complete address, including city, state, zip
- Name and phone number of remitter’s point of contact
- EPA docket number
- EPA contact name and phone number, if available
- Reason for payment

Note: It is important to direct payment to the appropriate EPA finance center to ensure your remittance is credited to the proper account. Each finance center has its own unique agency location code, and each U.S. depository has a unique bank routing number.

APPENDIX B

SUPPLEMENTAL ENVIRONMENTAL PROJECT DESCRIPTION



Forterra Pipe & Precast
840 West Avenue
Deland, Florida 32720
(386) 337-3932

June 22nd, 2017

Ms. Katherine Reitz
U.S. Environmental Protection Agency, Region 7
Office of Regional Counsel
11201 Renner Boulevard
Lenexa, KS 66219

**RE: Supplemental Environmental Project Work Plan
Forterra Concrete Products – Shawnee
23600 West 40th Street
Shawnee, KS 66226**

Dear Ms. Reitz:

Forterra Concrete Products, Inc. (Forterra) is pleased to provide this additional information for the Forterra Shawnee Supplemental Environmental Project Work Plan as documented in the May 22, 2017 email to your office (attached).

Currently due to site conditions stormwater from moving equipment travel lanes and storage areas stormwater sheet flows across the western outside production slabs. The proposed regrading of these travel lanes will redirect stormwater away for these outside production slabs toward the northern boundary berm of the facility, thus reducing stormwater run-on of the production slabs. This northern boundary of the facility is currently utilized for form and finished product storage on a compacted stone/aggregate base. A portion of the base material will be removed creating a 6'x650' drainage swale. The drainage swale will provide a vegetative swale for sedimentation as well as increasing available pervious area for infiltration. Sediment controls will be put into place to reduce dust and sediments from reaching the outfall. As an additional safeguard, a BioClean trash guard will be installed for inlet protection.

Forterra proposes the following Work Plan for the site improvements to the Shawnee (Bonner Springs) facility. Forterra will work with several contractors to complete the objectives of this work plan.

The work will be conducted in the following phases:

- Survey and Design
- Grading (Sediment and Erosion Control)
- Operation and Maintenance (Best Management Practices)

Survey and Design \$6,000

Forterra will have a local surveyor complete a topographic survey of the proposed drainage swale and outside pouring areas. This survey will allow Forterra to determine elevations to redirect stormwater

sheet flow away from impervious production and storage areas to the proposed drainage swale. The survey will include staking for the grading phase of the project and as-built drawing.

Grading \$16,880

Forterra will have a local site contractor create the proposed drainage swale (6'x650'), grade the areas around the outside pouring areas, provide sediment and erosion controls during the project, (\$15,380) and provide vegetative cover for the completed stormwater conveyance. (Hydro seeding \$1,500.00)

Operation and Maintenance \$2,000

Following the site work, Forterra will install a BioClean (a subsidiary of Forterra) trash guard (\$2,000 estimate) as additional inlet protection at the facility's drainage outfall. In addition, appropriate sediment controls (i.e. silt fence, straw wattles, filter socks) will be incorporated as best management practices to further reduce potential pollutants from reaching the facility's drainage outfall. The facility's Stormwater Pollution Prevention plan will also be updated to include the new stormwater conveyance and best management practices.

The estimated cost for the project as provided by the suppliers and subcontractors is \$24,880 with an expected timeline of 180-days following the execution of the CA/FO. The exact project cost will be provided via invoice copies following completion of the site work.

Please do not hesitate to contact me at 386-337-3932 or via email at Charles.Piwowarski@forterrabp.com.

Sincerely,



Mr. Charles Piwowarski
Area Environmental Manager
Forterra Building Products

cc: Erin Trainor – U.S. Environmental Protection Agency
Susan Richardson – Kilpatrick Townsend & Stockton LLP
Jack Horner, Todd Kepler – Forterra Concrete Products
Andre Deveau – Forterra

Attachment: Forterra Concrete Products – Shawnee Potential SEP email dated 05/22/2017

file:

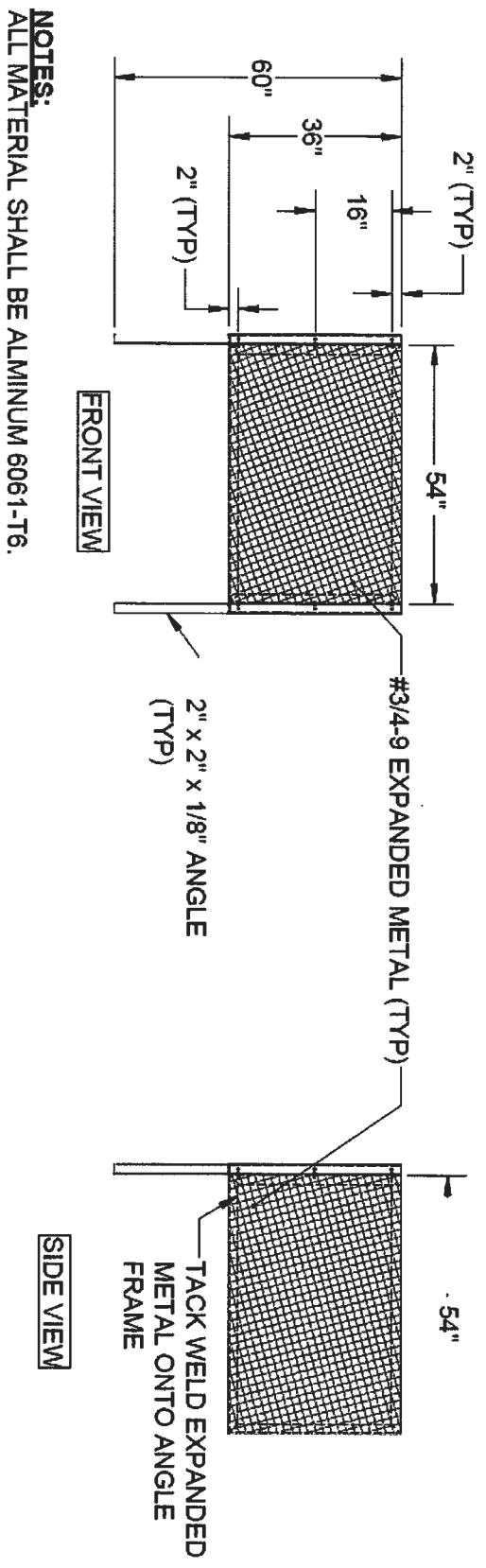
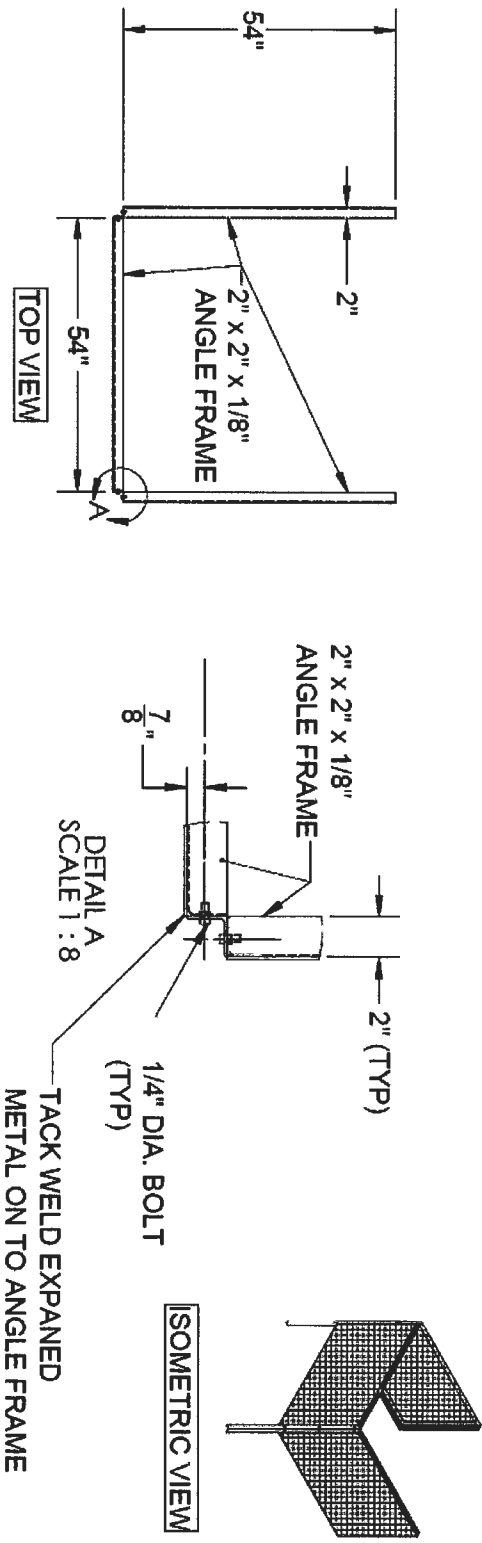

CERTIFICATE OF SERVICE

I certify that a true and correct copy of the foregoing Order was sent this day in the following manner to the addressees:

Copy emailed to Attorney for Complainant:

reitz.katherine@epa.gov

Copy by First Class Mail to Attorney for Respondent:

Susan Richardson
Kilpatrick Townsend & Stockton LLP
1100 Peachtree Street NE, Suite 2800
Atlanta, GA 30309-4528

Dated: Sept. 25, 2017

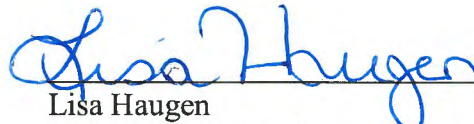

Lisa Haugen
Hearing Clerk, Region 7